

DENSELIGHT SEMICONDUCTORS PTE. LTD.
6 Changi North St. 2, S498831 SINGAPORE
Tel: (65) 64154488
Fax: (65) 64157988
www.denselight.com

SPECIFICATIONS

1690 nm Superluminescent LED

DL-CS69M5A

DenseLight Semiconductors reserves the right to make product design or specifications changes without notice.

A. PRODUCT DESCRIPTION

The DenseLight DL-CS69M5A series is a broadband SLED that operates in a true inherent superluminescent mode. This superluminescent property generates broader band at higher drive currents in contrast to other conventional SLEDs which are ASE-based, where high drive tends to give narrower band. Its low coherence reduces Rayleigh backscattering noise. Coupled with high power and large spectral width, it offsets photoreceiver noise and improves spatial resolution (in OCT) and measurand sensitivity (in sensors). The SLED is available in 14-pin BTF package. It is compliance with the requirements of Bellcore Document GR-468-CORE.

Enabled by DensePIC™ spread spectra bandgap engineering technology, future generations of DenseLight SLEDs promise higher chip powers (up to 50mW possible), and broader spectral bands (beyond 120nm). Higher levels of integration may feature integrated SLEDs with phase modulators, optical couplers and photodetectors into a complete optical sensor chipset.

For responsive prototyping enquiries please email: info@denselight.com

B. FEATURES

- Ex-fiber output power of >10mW
- 3dB bandwidth of >45nm
- Spectral modulation of <0.5dB
- 14-pin BTF package
- Single mode fiber

C. APPLICATIONS

- Fiber Optic Gyroscope
- Optical Test Instrument
- Fiber Optic Sensors
- Fiber Optic Communications
- Optical Coherence Tomography
- Biomedical Imaging Device
- Clinical Healing Equipment

14 JAN 2010



D. ABSOLUTE MAXIMUM RATINGS

Parameter	Symbol	Condition	Min	Max	Unit
Reverse voltage	V_R			2	V
Forward current	I_F			450	mA
Forward voltage	V_F	I_{op}		3	V
Case temperature	T_C	I_{op}	-40	65	°C
SLED temperature ¹	T_{SLED}	I_{op}	0	70	°C
Thermoelectric cooler voltage	V_{TEC}			3.56	V
Thermoelectric cooler current	I_{TEC}			2.6	A
Storage temperature	T_{stg}	Unbiased	-40	85	°C
Storage humidity			5	85	%RH
Electro static discharge (ESD)	V_{ESD}	Human body model		500	V
Lead soldering temperature	S_{temp}			260	°C
Lead soldering time	S_{time}			10	sec

E. SPECIFICATIONS ($T_{SLED} = 25\text{ °C}$)

Parameter	Symbol	Condition	Min	Typ	Max	Unit
Operating current	I_{op}			400	mA	
Forward voltage	V_F	I_{op}		2	V	
Power in SMF	P_D	I_{op}	10		mW	
Central wavelength	λ	I_{op}	1680	1690	1700	nm
Bandwidth	B_{FWHM}	I_{op}	45		nm	
Spectrum modulation	R	I_{op}			0.5	dB
Thermistor resistance	R_{therm}	$T = 25\text{ °C}$	9.5	10	10.5	k Ω
Thermoelectric cooler voltage	V_{TEC}	I_{op}		3	V	
Thermoelectric cooler current	I_{TEC}	I_{op}		1.8	A	

¹ T_{SLED} is monitored by internal thermistor with external pin out.

F. PACKAGE

BTF package

Part	Description
Package type	BTF
Fiber:	SMF-28
	10 μ m
	MFD
	Cladding diameter
	125 μ m
	Coating diameter
	245 μ m
	Jacket
	900 μ m loose tube
Fiber pigtail length	1m
Fiber bending radius	>40mm
Connector	FC/APC
Dimensions	See figure

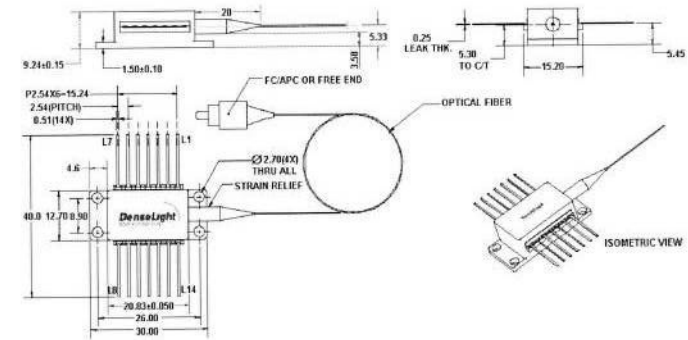

Pin Assignment	
1	TEC+
2	THERMISTOR
3	-
4	-
5	THERMISTOR
6	-
7	-
8	-
9	-
10	SLED ANODE +
11	SLED CATHODE -
12	-
13	CASE
14	TEC -

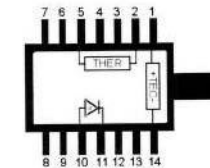

G. TYPICAL PERFORMANCE CHARACTERISTICS

Operating condition: $T_{SLED} = 25\text{ }^{\circ}\text{C}$

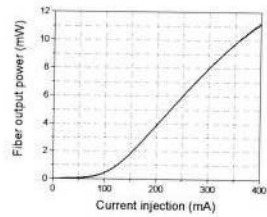

P-I Curve

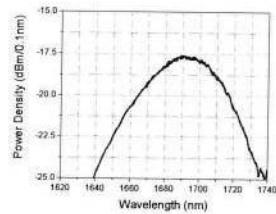

Spontaneous Emission Spectrum

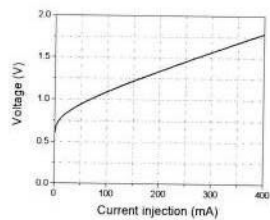

I-V Curve

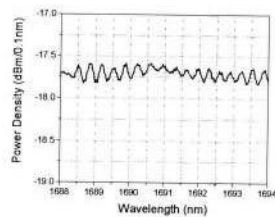

Spectrum Modulation

14 JAN 2010

