

## MODULATOR

# NIR-MPX and NIR-MPZ Series

## 1000 nm band Phase Modulators

The Exail NIR-MP series are phase modulators especially designed to operate in the 1000 nm wavelength band. They are available with various modulation bandwidths, from low frequency to 30 GHz and beyond. Like all Exail Near InfraRed (NIR) modulators, the NIR-MP series use a proton exchanged based waveguide process that confers them an unparalleled stability even when operating at high optical power and large range of temperature. The NIR-MP phase modulators come with high PER and Low Insertion Loss options.



### Features

- High optical power up to 28 dBm
- High bandwidth version > 30 GHz
- High stability vs optical power
- Low  $V_{\pi}$
- Low insertion loss

### Applications

- Interferometric based sensors
- Spectral broadening
- Laser combining
- Pound-Drever-Hall locking (PDH)
- Optical comb

### Options

- High PER
- Lower Residual Amplitude Modulation
- Space grade version (TRL9)

### Related Equipments

- Matched RF amplifiers
- NIR-MX intensity modulators
- Spectral Broadening ModBox-sb
- Coherent Beam Combining ModBox-

### NIR-MPX-LN-0.1 Performance Highlights

Parameter	Min	Typ	Max	Unit
Operating wavelength	950	-	1150	nm
Usable EO bandwidth	-	300	-	MHz
$V_{\pi}$ RF @50 kHz	-	1.5	2	V

### NIR-MPX-LN-02 Performance Highlights

Parameter	Min	Typ	Max	Unit
Operating wavelength	950	-	1150	nm
Usable EO bandwidth	-	5	-	GHz
$V_{\pi}$ RF @50 kHz	-	1.5	2	V

### NIR-MPX-LN-05 Performance Highlights

Parameter	Min	Typ	Max	Unit
Operating wavelength	950	-	1150	nm
Usable EO bandwidth	-	10	-	GHz
$V_{\pi}$ RF @50 kHz	-	4	-	V

### NIR-MPX-LN-10 Performance Highlights

Parameter	Min	Typ	Max	Unit
Operating wavelength	950	-	1150	nm
Usable EO bandwidth	-	16	-	GHz
$V_{\pi}$ RF @50 kHz	-	5	-	V

### NIR-MPZ-LN-20 Performance Highlights

Parameter	Min	Typ	Max	Unit
Operating wavelength	950	-	1150	nm
Usable EO bandwidth	-	30	-	GHz
$V_{\pi}$ RF @50 kHz	-	3.5	-	V

# NIR-MPX-LN-0.1

## 300 MHz Phase Modulator

### Electrical Characteristics

Parameter	Symbol	Condition	Min	Typ	Max	Unit
Electro-optical (EO) bandwidth	$S_{21}$	-	150	-	-	MHz
Usable EO bandwidth	$t_r / t_f$	-		300	-	MHz
$V_{\pi}$ RF @50 kHz	$V_{\pi_{RF\ 50\ kHz}}$	RF electrodes	-	1.5	2	V
RF input impedance	$Z_{in-RF}$	-	-	10 000	-	$\Omega$

### Optical Characteristics

Parameter	Symbol	Condition	Min	Typ	Max	Unit
Crystal	-	-	Lithium Niobate X-Cut Y-Prop			
Waveguide process	-	-	Proton exchange			
Operating wavelength	$\lambda$	-	950	1060	1150	nm
Insertion loss	IL	Without connectors*	-	3	4	dB
Low insertion loss	LIL	Without connectors*	-	-	3	dB
Polarization Extinction ratio	PER	Standard, Without connectors*	20	-	-	dB
		Optional, w/ or w/o connectors*	25	30	-	dB
Optical return loss	ORL	-	-40	-45	-	dB

All specifications given at 25°C, 1060 nm, unless differently specified.

\* Consider an extra-loss up to 0.4 dB for each FC/APC optical connector

### Absolute Maximum Ratings

Stresses in excess of the absolute maximum ratings can cause permanent damage to the device. These are absolute stress ratings only. Functional operation of the device is not implied at these or any other conditions in excess of those given in the operational sections of the data sheet. Exposure to absolute maximum ratings for extended periods can adversely affect device reliability.

Parameter	Symbol	Min	Max	Unit
Modulation voltage range	$EV_{in}$	-20	+20	V
Optical input power (CW mode)	$OP_{in}$	-	+25	dBm
Operating temperature	OT	0	+70	°C
Storage temperature	ST	-40	+85	°C

# NIR-MPX-LN-02

## 5 GHz Phase Modulator

### Electrical Characteristics

Parameter	Symbol	Condition	Min	Typ	Max	Unit
Electro-optical (EO) bandwidth	$S_{21}$	-	2	-	-	GHz
Usable EO bandwidth	$S_{21}$	-	-	5	-	GHz
Ripple $S_{21}$	$\Delta S_{21}$	-	-	0.5	1	dB
Electrical return loss	$S_{11}$	-	-	-10	-8	dB
V $\pi$ RF @50 kHz	$V_{\pi RF 50 kHz}$	-	-	1.5	2	V
RF input impedance	$Z_{in-RF}$	-	-	50	-	$\Omega$

### Optical Characteristics

Parameter	Symbol	Condition	Min	Typ	Max	Unit
Crystal	-	-	Lithium Niobate X-Cut Y-Prop			
Waveguide process	-	-	Proton exchange			
Operating wavelength	$\lambda$	-	950	1060	1150	nm
Insertion loss	IL	Without connectors*	-	3	4	dB
Low insertion loss	LIL	Without connectors*	-	-	3	dB
Polarization Extinction ratio	PER	Standard, without connectors*	20	-	-	dB
		Optional, w/ or w/o connectors*	25	30	-	dB
Optical return loss	ORL	-	-40	-45	-	dB

All specifications given at 25°C, 1060 nm, unless differently specified.

<sup>(1)</sup> Consider an extra-loss up to 0.4 dB for each FC/APC optical connector

### Absolute Maximum Ratings

Stresses in excess of the absolute maximum ratings can cause permanent damage to the device. These are absolute stress ratings only. Functional operation of the device is not implied at these or any other conditions in excess of those given in the operational sections of the data sheet. Exposure to absolute maximum ratings for extended periods can adversely affect device reliability.

Parameter	Symbol	Min	Max	Unit
Modulation voltage range	$EV_{in}$	-	+33	dBm
Optical input power (CW mode)	$OP_{in}$	-	+25	dBm
Operating temperature	OT	0	+70	°C
Storage temperature	ST	-40	+85	°C

# NIR-MPX-LN-05

## 10 GHz Phase Modulator

### Electrical Characteristics

Parameter	Symbol	Condition	Min	Typ	Max	Unit
Electro-optical (EO) bandwidth	$S_{21}$	-	5	-	-	GHz
Usable EO bandwidth	$S_{21}$	-	-	10	-	GHz
Ripple $S_{21}$	$\Delta S_{21}$	-	-	0.5	1	dB
Electrical return loss	$S_{11}$	-	-	-12	-10	dB
$V_{\pi}$ RF @50 kHz	$V_{\pi_{RF\ 50\ kHz}}$	-	-	4	5	V
RF input impedance	$Z_{in-RF}$	-	-	50	-	$\Omega$

### Optical Characteristics

Parameter	Symbol	Condition	Min	Typ	Max	Unit
Crystal	-	-	Lithium Niobate X-Cut Y-Prop			
Waveguide process	-	-	Proton exchange			
Operating wavelength	$\lambda$	-	950	1060	1150	nm
Insertion loss	IL	Without connectors*	-	3	4	dB
Low insertion loss	LIL	Without connectors*	-	-	3	dB
Polarization Extinction ratio	PER	Standard, without connectors*	20	-	-	dB
		Optional, w/ or w/o connectors*	25	30	-	dB
Optical return loss	ORL	-	-40	-45	-	dB

All specifications given at 25°C, 1060 nm, unless differently specified.

<sup>(1)</sup> Consider an extra-loss up to 0.4 dB for each FC/APC optical connector

### Absolute Maximum Ratings

Stresses in excess of the absolute maximum ratings can cause permanent damage to the device. These are absolute stress ratings only. Functional operation of the device is not implied at these or any other conditions in excess of those given in the operational sections of the data sheet. Exposure to absolute maximum ratings for extended periods can adversely affect device reliability.

Parameter	Symbol	Min	Max	Unit
Modulation voltage range	$EP_{in}$	-	+33	dBm
Optical input power (CW mode)	$OP_{in}$	-	+25	dBm
Operating temperature	OT	0	+70	°C
Storage temperature	ST	-40	+85	°C

# NIR-MPX-LN-10

## 18 GHz Phase Modulator

### Electrical Characteristics

Parameter	Symbol	Condition	Min	Typ	Max	Unit
Electro-optical (EO) bandwidth	$S_{21}$	-	10	12	-	GHz
Usable EO bandwidth	$S_{21}$	-	16	18	-	GHz
Ripple $S_{21}$	$\Delta S_{21}$	-	-	0.5	1	dB
Electrical return loss	$S_{11}$	-	-	-12	-10	dB
V $\pi$ RF @50 kHz	$V_{\pi RF 50 kHz}$	-	-	5	6	V
RF input impedance	$Z_{in-RF}$	-	-	50	-	$\Omega$

### Optical Characteristics

Parameter	Symbol	Condition	Min	Typ	Max	Unit
Crystal	-	-	Lithium Niobate X-Cut Y-Prop			
Waveguide process	-	-	Proton exchange			
Operating wavelength	$\lambda$	-	950	1060	1150	nm
Insertion loss	IL	Without connectors*	-	3	4	dB
Low insertion loss	LIL	Without connectors*	-	-	3	dB
Polarization Extinction ratio	PER	Standard, without connectors*	20	-	-	dB
		Optional, w/ or w/o connectors*	25	30	-	dB
Optical return loss	ORL	-	-40	-45	-	dB

All specifications given at 25°C, 1060 nm, unless differently specified.

<sup>(1)</sup> Consider an extra-loss up to 0.4 dB for each FC/APC optical connector

### Absolute Maximum Ratings

Stresses in excess of the absolute maximum ratings can cause permanent damage to the device. These are absolute stress ratings only. Functional operation of the device is not implied at these or any other conditions in excess of those given in the operational sections of the data sheet. Exposure to absolute maximum ratings for extended periods can adversely affect device reliability.

Parameter	Symbol	Min	Max	Unit
Modulation voltage range	$EV_{in}$	-	+33	dBm
Optical input power (CW mode)	$OP_{in}$	-	+25	dBm
Operating temperature	OT	0	+70	°C
Storage temperature	ST	-40	+85	°C

# NIR-MPZ-LN-20

## 30 GHz Phase Modulator

### Electrical Characteristics

Parameter	Symbol	Condition	Min	Typ	Max	Unit
Electro-optical (EO) bandwidth	$S_{21}$	-	16	20	-	GHz
Usable EO bandwidth	$S_{21}$	-	-	30	-	GHz
Ripple $S_{21}$	$\Delta S_{21}$	-	-	0.5	1	dB
Electrical return loss	$S_{11}$	-	-	-13	-10	dB
$V_{\pi}$ RF @50 kHz	$V_{\pi_{RF50\text{ kHz}}}$	-	-	3.5	4	V
$V_{\pi}$ RF @20 GHz	$V_{\pi_{RF20\text{ GHz}}}$	-	-	6	-	V
RF input impedance	$Z_{in-RF}$	-	-	50	-	$\Omega$

### Optical Characteristics

Parameter	Symbol	Condition	Min	Typ	Max	Unit
Crystal	-	-	Lithium Niobate Z-Cut Y-Prop			
Waveguide process	-	-	Proton exchange			
Operating wavelength	$\lambda$	-	950	1060	1150	nm
Insertion loss	IL	Without connectors*	-	3	4	dB
Low insertion loss	LIL	Without connectors*	-	2.5	3	dB
Polarization Extinction ratio	PER	Standard, without connectors*	20	-	-	dB
Optical return loss	ORL	-	-40	-45	-	dB

All specifications given at 25 °C, 1060 nm, unless differently specified.

\* Consider an extra-loss up to 0.4 dB for each FC/APC optical connector

### Absolute Maximum Ratings

Stresses in excess of the absolute maximum ratings can cause permanent damage to the device. These are absolute stress ratings only. Functional operation of the device is not implied at these or any other conditions in excess of those given in the operational sections of the data sheet. Exposure to absolute maximum ratings for extended periods can adversely affect device reliability.

Parameter	Symbol	Min	Max	Unit
RF input power (CW mode)	$EP_{in}$	-	+33	dBm
Optical input power (CW mode)	$OP_{in}$	-	+25	dBm
Operating temperature	OT	-30	+70	°C
Operating temperature variation rate	$OT_{vr}$	-	1	°C/min
Storage temperature	ST	-40	+85	°C
Vibration	Vib	MIL-STD-883J method 2007.3 - Test condition B		
Mechanical shock	Shock	MIL-STD-882J method 2002.5 - Test condition B		

# MODULATOR | NIR-MPX/MPZ-LN SERIES | 7/7

## Mechanical Diagram and Pinout

All measurements in mm

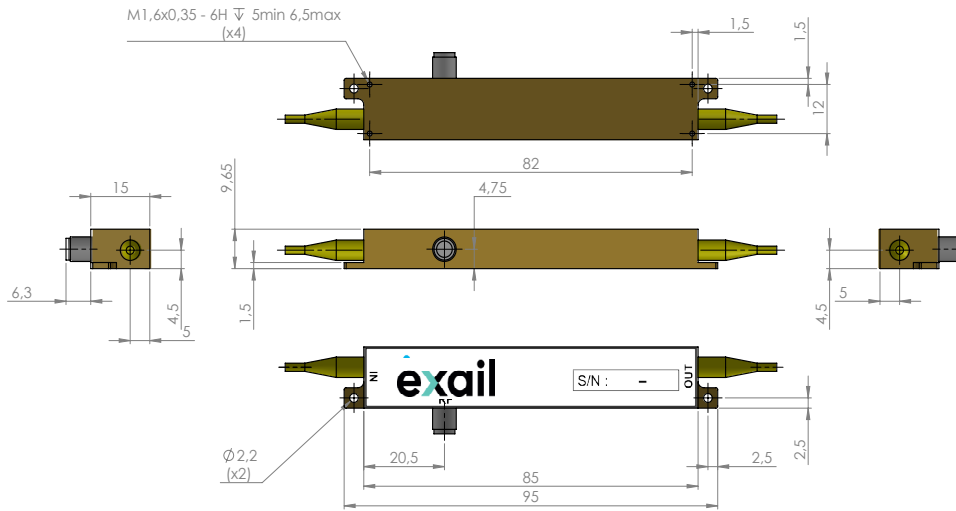

Port	Function	Note
IN	Optical input port	Polarization maintaining fiber Corning PM 98-U25D Length: 1.5 meter, buffer diameter: 900 µm
OUT	Optical output port	Polarization maintaining fiber Corning PM 98-U25D Length: 1.5 meter, buffer diameter: 900 µm
RF	RF input port	Female K

## Ordering information

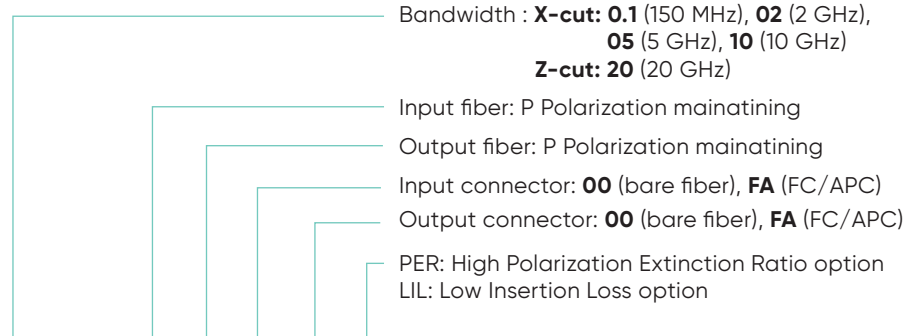

NIR-MPX/MPZ-LN-□-00-□-□-□-□-□

## About us

Exail Photonics produces specialty optical fibers and Bragg gratings based fiber optics components and provides optical modulation solutions based on the company lithium niobate (LiNbO<sub>3</sub>) modulators and RF electronic modules. Exail Photonics serves a wide range of industries: sensing and instruments, defense, telecommunications, space and fiber lasers as well as research laboratories all over the world.

Exail reserves the right to change, at any time and without notice, the specifications, design, function or form of its products described herein. All statements, specification, technical information related to the products herein are given in good faith and based upon information believed to be reliable and accurate at the moment of printing. **However, Exail provides no warranty (whether express or implied or statutory) as to the description, sufficiency, accuracy or completeness, merchantability or fitness for a particular purpose of any information or specification detailed herein.** No liability is assumed for any inaccuracies and/or as a result of use of the products. The user must validate all parameters for each application before any use and he shall assume all risks and responsibilities in connection with the use of the products.