

25Gb/s Photodiode Chip

CPF0003A

Features

- Top illuminated InGaAs/InP p-i-n PD
- Coplanar GSG contact pads
- Low cost and High reliability

Applications

- Receiver for 100GbE and OTU4
- Datacom and Telecom up to 28Gb/s

Absolute Maximum Ratings

Parameters	Symbol	Rating	Unit
Reverse voltage	V_R	20	V
Reverse current	I_R	2	mA
Forward current	I_F	10	mA
Optical input power	P_{max}	5	dBm
Operating temperature range	T_C	-40 to +85	°C
Storage temperature range	T_{STG}	-40 to +125	°C

Electro-Optical Characteristics

Parameters	Symbol	Test Condition	Min.	Typ.	Max.	Unit
Operating wavelength range	λ	-	1100	-	1640	nm
Responsivity*	R	1310nm, $V_R=2.5V$	0.7	0.8	-	A/W
Dark current	I_D	$V_R=5V$	-	1	10	nA
OE Bandwidth	BW	-3dB electrical	18	22	-	GHz
Total capacitance	C	$f=1MHz$, $V_R=2.5V$	-	0.11	0.15	pF

* depend on optical coupling efficiency

Dimensions

Parameters	Symbol	Test Condition	Unit
Optical aperture diameter	D	20	μm
Chip size	W x H	350 x 350	μm^2
Chip thickness	T	150±20	μm
Bonding pad size	-	80 x 80	μm

(unit: μm)

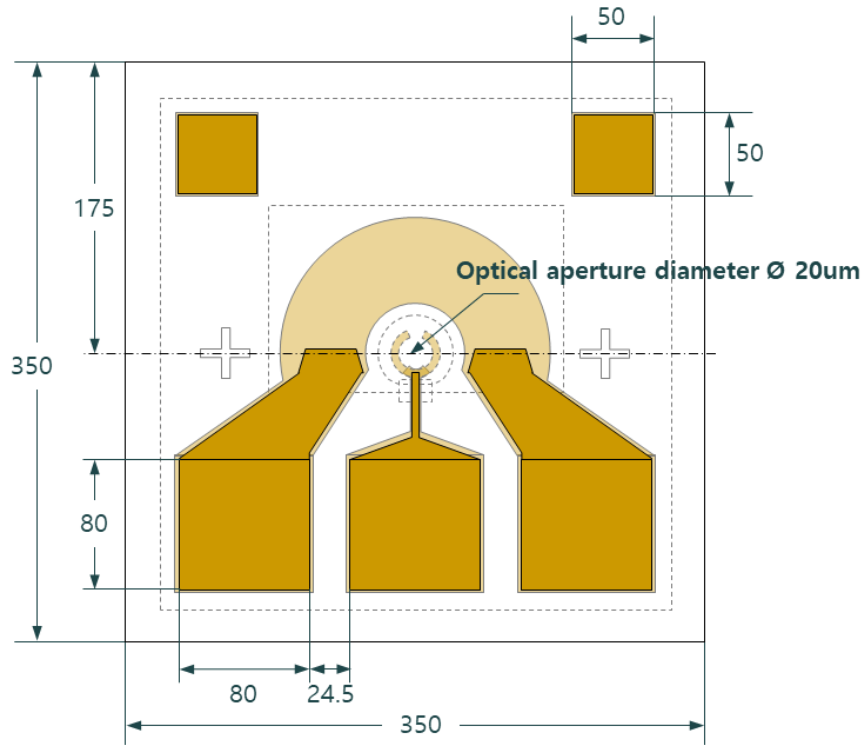

Precaution to use

The CPC0003A is sensitive to electrostatic discharge (ESD) and should be handled with appropriate caution. Please use standard ESD protective equipment when handling this product.

Ordering information

CPF0003A

Specifications described here are subject to change without notice



Tel: +82-62-602-8100

www.wooriro.com

support@wooriro.com