

## 1060nm DFB Laser diode for Seed Laser

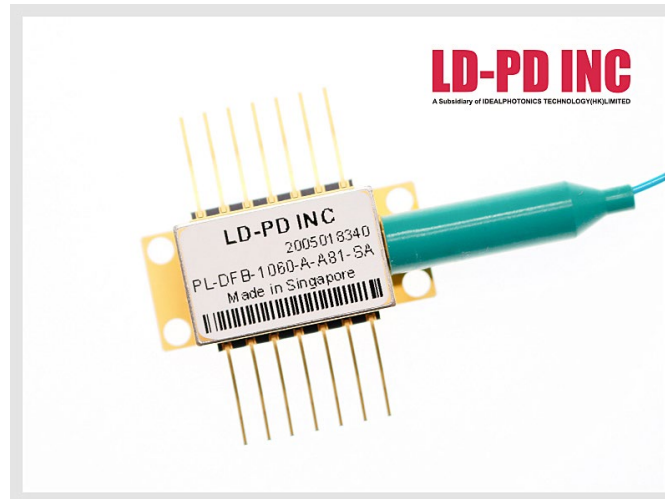

### Description:

The PL-DFB-1060-A-A81 1060nm DFB laser diode module made by LD-PD is a cost effective, highly coherent laser source. The DFB laser diode chip is packaged in an industry standard hermetically sealed 14 pin butterfly package with TEC and PD Built in.

### Features:

- Narrow Linewidth < 2MHz
- Excellent wavelength control and stability
- Industry Standard 14 pin Butterfly package
- Mode-Hop free tuning
- Excellent reliability
- Customer specific wavelengths available

### Applications:

- Tunable diode laser absorption spectroscopy
- Seed laser
- Fiber laser

## Electrical/Optical Characteristics:

(Tsub=25°C, CW bias unless stated otherwise)

Parameter	Symbol	Min	Typ	Max	Unit
Centre Wavelength	$\lambda$	1059.5	1060.0	1060.5	nm
Side Mode Suppression Ratio	SMSR	30	40		dB
Threshold Current	I <sub>th</sub>		20	30	mA
Operating Current	I <sub>op</sub>		250	350	mA
Chip output Power	P <sub>f</sub>	30	40	50	mW
Quantum Efficiency	$\eta$	0.08	0.12		mW/mA
Current Tuning Coefficient	$\lambda / I$		0.015		nm/mA
Temperature Tuning Coefficient	$\lambda / T$		0.12		nm/K
Forward Voltage	V <sub>f</sub>		1.3	2	V
Thermistor Resistance	RT	9.5	10	10.5	K $\Omega$
Thermistor Temp. Coefficient			-4.4		%/°C
Connector	FC/APC				

## Spectrum:

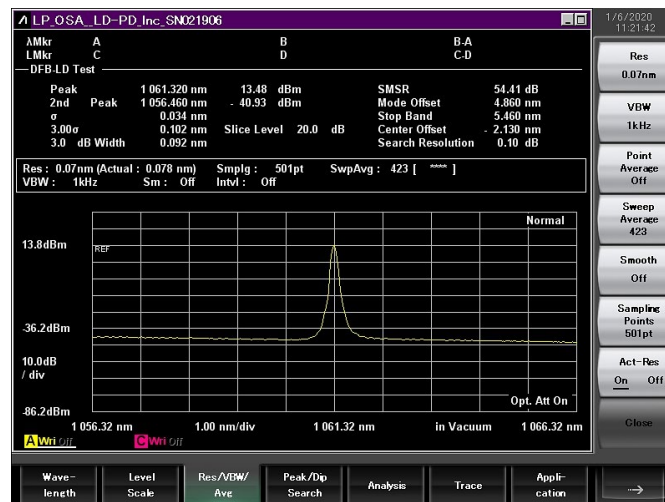

**L-I Curve:**

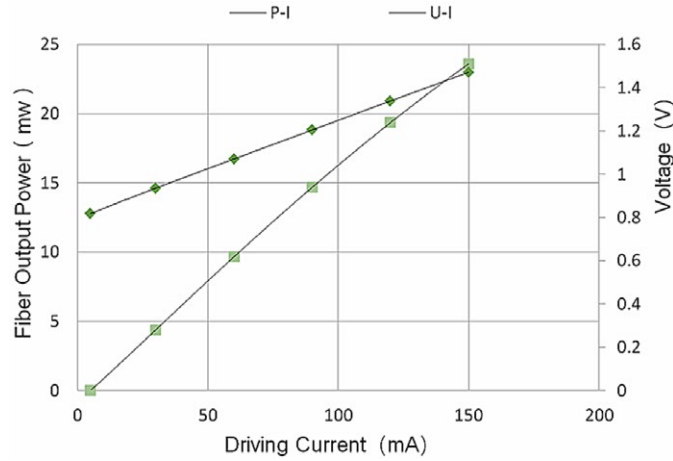

**DFB Linewidth Testing Result:**

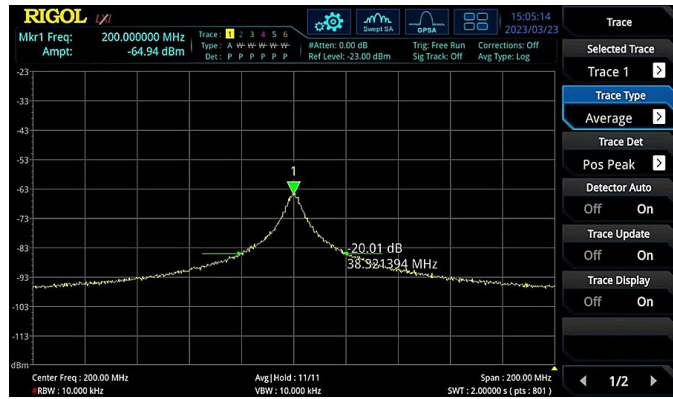

**Tuning Characteristics:**

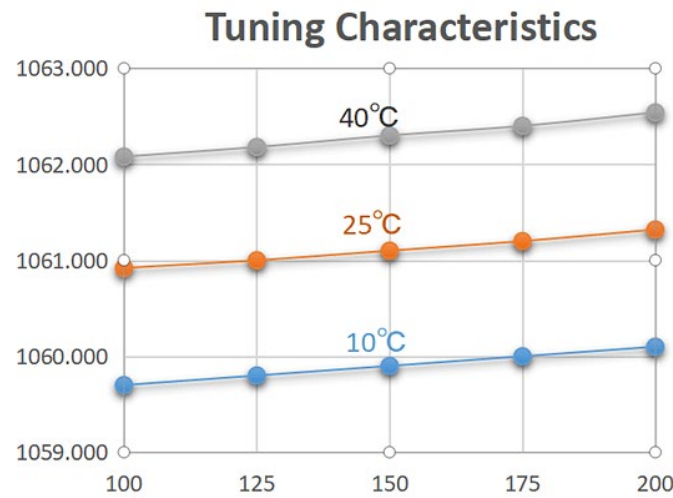

**Package Size:**

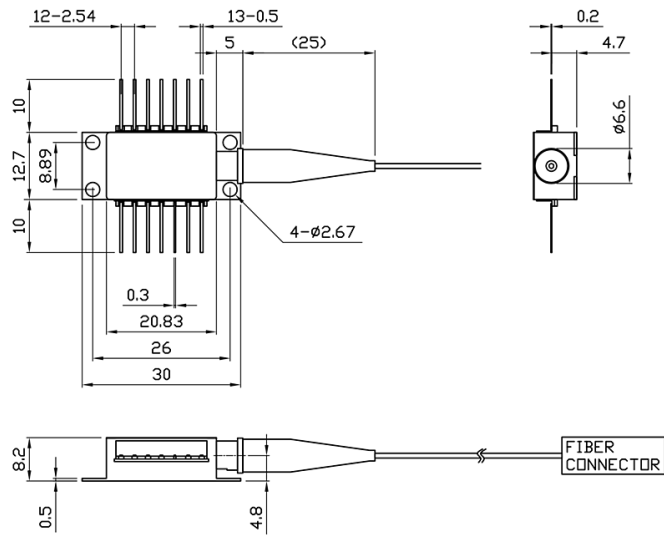

**Pin definition:**

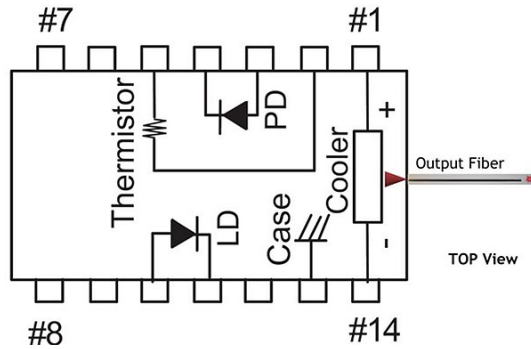

1	Thermoelectric Cooler (+)	8	N/C
2	Thermistor	9	N/C
3	PD Monitor Anode (-)	10	Laser Anode (+)
4	PD Monitor Cathode (+)	11	Laser Cathode (-)
5	Thermistor	12	N/C
6	N/C	13	Case Ground
7	N/C	14	Thermoelectric Cooler (-)

## Absolute Maximum Ratings:

Item	Unit	Min	Typ	Max
Case Temperature	°C	-5	25	70
Chip Temperature	°C	+10	25	40
Operating Current	mA	0	250	350
Forward Voltage	V	0.8	1.2	2.1
TEC Current	A	-	1.2	1.2
Reverse Voltage(LD)	V	-	-	2.0
Reverse Voltage(PD)	V	-	-	20

## Ordering Info:

PL-DFB-□□□□-☆-A8▽-XX

□□□□: Wavelength

1064: 1064nm

1532: 1532nm

1392: 1392nm

1512: 1512nm

1567: 1567nm

\*\*\*\*\*

1653.7: 1653.7nm

☆: Output Power

A: 40mW

B: 70mW

▽: Wavelength Tolerance

1: ±1nm

2: ±2nm

XX: Fiber and Connector Type

SA=HI1060+ FC/APC

SP=HI1060+ FC/PC

PA=PM980 Fiber+ FC/APC

PP=PM980 Fiber+ FC/PC