

760nm DFB Laser diode for O2 Sensing

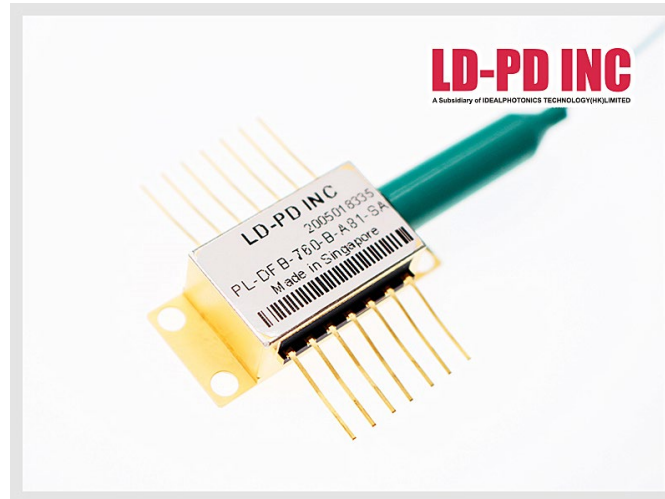

Description:

The PL-DFB-760-A-A81 760nm DFB laser diode module made by LD-PD is a cost effective, highly coherent laser source. The DFB laser diode chip is packaged in an industry standard hermetically sealed 14 pin butterfly package with TEC and PD Built in.

Features:

- Narrow Linewidth < 2MHz
- Excellent wavelength control and stability
- Industry Standard 14 pin Butterfly package
- Mode-Hop free tuning
- Excellent reliability
- Customer specific wavelengths available

Application:

- Tunable diode laser absorption spectroscopy
- O₂ Monitoring

Laser Specifications:

Electrical/Optical Characteristics (Tsub=25 °C , CW bias unless stated otherwise)

Parameter	Symbol	Min	Typ	Max	Unit
Centre Wavelength	λ	759.0	760.0	761.0	nm
Side Mode Suppression Ratio	SMSR	30	40		dB
Threshold Current	I _{th}		5	10	mA
Operating Current	I _{op}		40	50	mA
Chip output Power	P _f	4	5	8	mW
Quantum Efficiency	η	0.08	0.12		mW/mA
Current Tuning Coefficient	$\Delta \lambda / \Delta I$		0.015		nm/mA
Temperature Tuning Coefficient	$\Delta \lambda / \Delta T$		0.12		nm/K
Forward Voltage	V _f		1.3	2	V
Thermistor Resistance	RT	9.5	10	10.5	K Ω
Thermistor Temp. Coefficient			-4.4		%/°C
Fiber+Connector	HI780+FC/APC				

Spectrum:

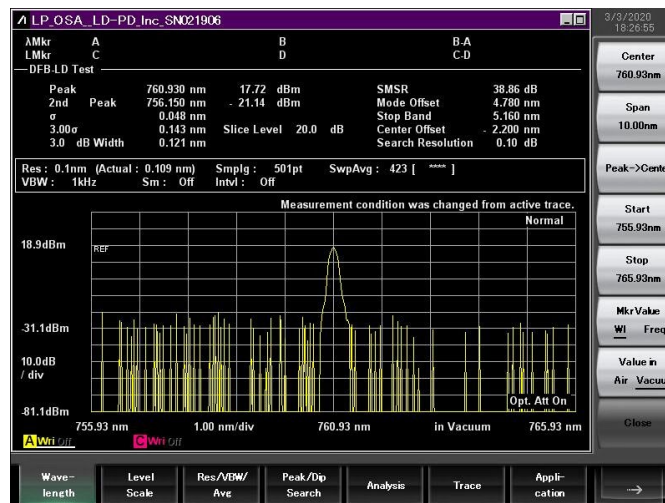

Tuning Characteristics:

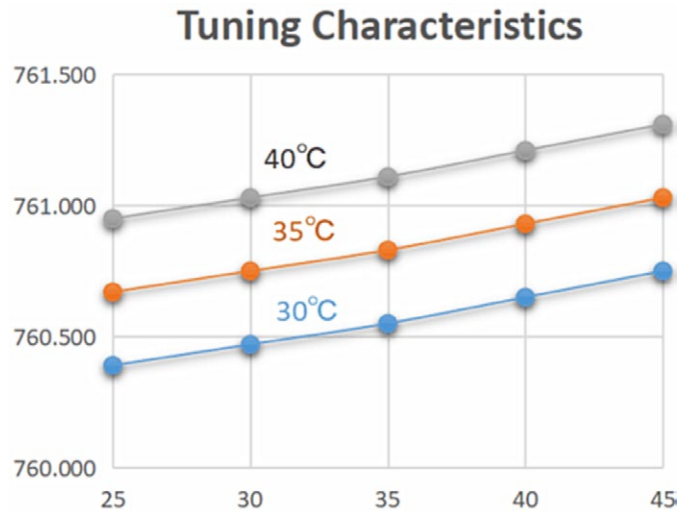

DFB Linewidth Testing Result:

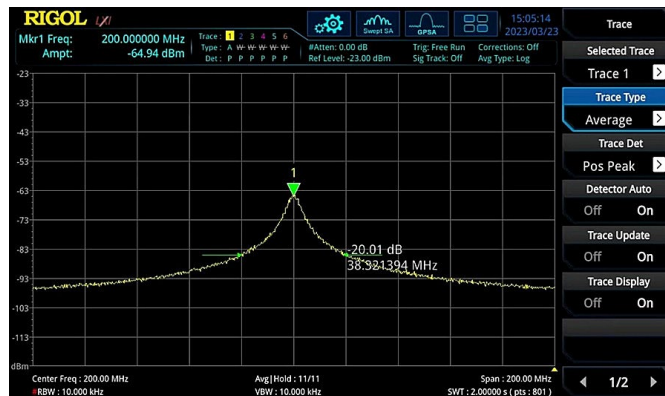

L-I Curve:

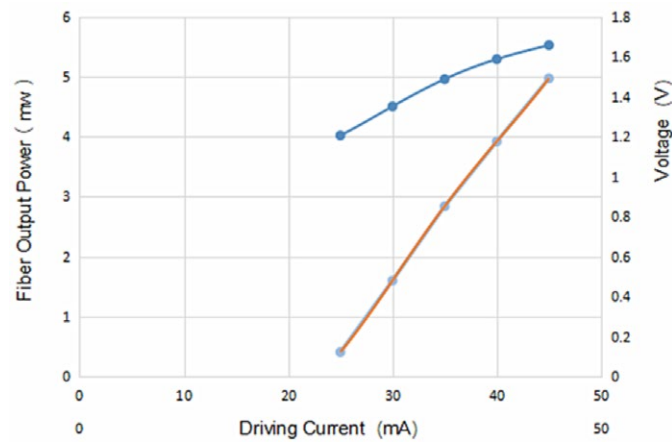

Package Size:

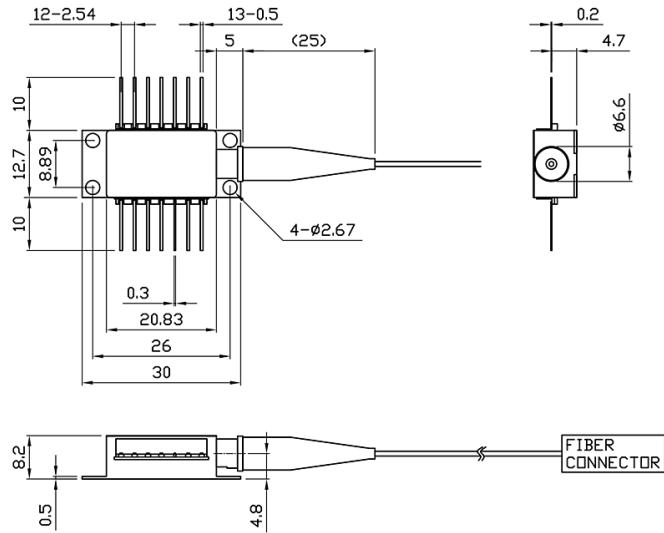

Pin definition:

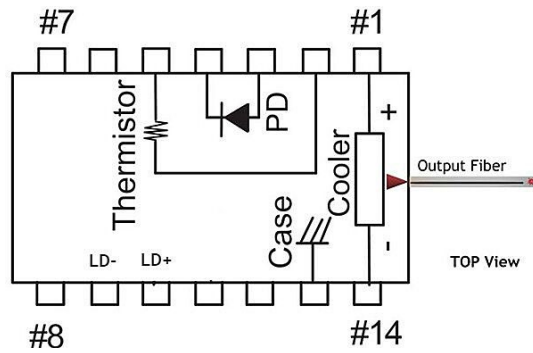

PIN#	Function	PIN#	Function
1	Thermoelectric Cooler (+)	8	N/C
2	Thermistor	9	Laser Cathode (-)
3	PD Monitor Anode (-)	10	laser Anode (+)
4	PD Monitor Cathode (+)	11	N/C
5	Thermistor	12	N/C
6	N/C	13	Case Ground
7	N/C	14	Thermoelectric Cooler (-)

Absolute Maximum Ratings:

Item	Unit	Min	Typ	Max
Case Temperature	°C	-5	25	70
Chip Temperature	°C	+10	25	50
Operating Current	mA	0	40	50
Forward Voltage	V	0.8	1.2	1.8
TEC Current	A	-	1.2	2.0
Reverse Voltage (LD)	V	-	-	2.0

Ordering Info:

PL-DFB-□□□□-☆-A8▽-XX

□□□□: Wavelength

760: 760nm

1270: 1270nm

1532:1532nm

1392:1392nm

1512:1512nm

1567:1567nm

1653.7: 1653.7nm

☆ : Output Power

A: 5mW

B: 10mW

▽ : Wavelength Tolerance

1: ± 1nm

2: ± 2nm

XX: Fiber and Connector Type

SA=HI780+ FC/APC

SP=HI780+ FC/PC

PP=PM 850Fiber+ FC/PC

PA=PM 850Fiber+ FC/APC