

 瑞波光电 RAYBOW OPTO	RB-905E-300-225-0.75-TO-S1-G90 产品规格书 www.raybowlaser.com	文件编号	RB-PN-10009283
		版本号	V 2.0
		页码	1 / 9

深圳瑞波光电电子有限公司

RB-905E-300-225-0.75-TO-S1-G90 技术规格书

 瑞波光电 RAYBOW OPTO	RB-905E-300-225-0.75-TO-S1-G90 产品规格书 www.raybowlaser.com	文件编号	RB-PN-10009283
		版本号	V 2.0
		页码	3 / 9

Pulsed Laser Diode in TO56 Package with FAC

905 nm 225 w 脉冲半导体激光器件

■ Applications | 应用

- LiDAR 激光雷达
- Laser ranging 激光测距
- Safety monitoring 安全监控
- Scientific research test 科研实验

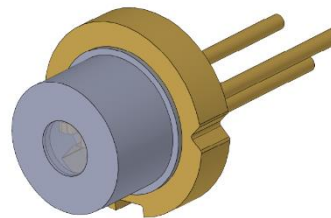

■ Features | 产品特点

- | | |
|---|---------------------------------|
| ·5stack PLD | 5 个发光层 |
| ·Laser wavelength: 905 nm | 激射波长: 905 nm |
| ·Peak output power: ≥225 w | 峰值功率: ≥225 w |
| ·Laser aperture (FWHM) size: 240 μm x 19 μm | 发光窗口 (半高全宽) 尺寸 : 240 μm x 19 μm |
| ·Laser aperture (enclosed 95%E) size : 300 μm | 发光窗口 (包含 95%能量) 宽度 : 300 μm |

■ Ordering Information | 订购信息

Model 型号	Peak output power tpy. 峰值功率 典型值	Description 描述
RB-905E-300-225-0.75-TO-S1-G90	225 w	准直的波长低温漂 225W-TO56

 瑞波光电 RAYBOW OPTO	RB-905E-300-225-0.75-TO-S1-G90 产品规格书 www.raybowlaser.com	文件编号	RB-PN-10009283
		版本号	V 2.0
		页码	4 / 9

■ Absolute Maximum Ratings($T_{rt}=25^{\circ}\text{C}$) 极限值

Parameter 参数	Symbol 符号	Values 数值	Unit 单位
Operation Current 工作电流 ▼	I_{op}	45	A
Reverse Voltage 反向电压 ▼	V_r	20	V
Pulsed Duration 脉冲宽度 ▼	P_w	100	ns
Duty Ratio 占空比 ▼	D_R	0.1	%
Operation Temperature 工作温度	T_{op}	-40~85	$^{\circ}\text{C}$
Storage Temperature 存储温度	T_{stg}	-40~105	$^{\circ}\text{C}$
Soldering Temperature 焊接温度 ▼	T_s	≤ 260	$^{\circ}\text{C}$

■ Characteristics ($T_{rt}=25^{\circ}\text{C}$) 参数值

$I_{op}=39\text{ A}, P_w=200\text{ ns}, f=5\text{ kHz}, D_R=0.1\%, T_{op}=25^{\circ}\text{C}$					
Parameter 参数	Symbol 符号	Min. 最小值	Typ. 典型值	Max. 最大值	Unit 单位
Wavelength 波长					
Peak Emission Wavelength 峰值波长	λ_{op}	895	905	915	nm
Spectral Bandwidth ^② 光谱宽度 ▼	BW	5	7	8	nm
Wavelength Temperature Coefficient 温漂系数	$\Delta\lambda/\Delta T$	-	0.065	0.09	nm/ $^{\circ}\text{C}$
Electro Optical Data 光电参数					
Operation Power 工作功率 ▲	P_{op}	-	225	-	w
Operation Current	I_{op}	38	39	40	A
Turn-on Voltage 开启电压	V_{on}	-	6.8	-	V
Series Resistance 串联电阻 ▼	R_s	-	0.60	-	Ω
Threshold Current 阈值电流	I_{th}	-	0.8	-	A
Operation Voltage 工作电压 ▼	V_{op}	23	24.6	26.2	V
Beam Divergenc(95%E)parallel to pn-junction ^① 包含 95% 能量的水平发散角宽度 ▼	$\theta_{//}$	12	13	16	degrees
Beam Divergenc(FWHM)parallel to pn-junction ^② 半高全宽的水平发散角宽度 ▼	$\theta_{//}$	9	10	11	degrees

 瑞波光电 RAYBOW OPTO	RB-905E-300-225-0.75-TO-S1-G90 产品规格书 www.raybowlaser.com	文件编号	RB-PN-10009283
		版本号	V 2.0
		页码	5 / 9

Beam Divergenc(95%E) perpendicular to pn-junction ^① 包含 95% 能量的垂直发散角宽度▼	θ_{\perp}	11	12	14	degrees
Beam Divergenc(FWHM) perpendicular to pn-junction ^② 半高全宽的垂直发散角宽度▼	θ_{\perp}	10	11	13	degrees
Beam Pointing Angle (Horizontal) 水平方向指向角度▼	$\theta_{//,p}$	-3	0	+3	degrees
Beam Pointing Angle (Vertical) 垂直方向指向角度▼	$\theta_{\perp,p}$	-3	0	+3	degrees
Geometrical 尺寸					
Laser Aperture (95%E) Size ^① 包含 95% 能量的发光窗口宽度	w	-	300	-	μm
Laser Aperture (FWHM) Size ^② 半高全宽的发光窗口尺寸	w x h	-	240 x 19	-	μm^2
Cavity Length 腔长	L	-	750	-	μm
Chip Width 宽度	W	-	400	-	μm
Chip Height 厚度	H	-	150	-	μm

Notes 备注：①Full width at 95% power content 涵盖 95% 能量宽度；②Full Width at half maxima 半高全宽 FWHM

③望大▲，望小▼；



RB-905E-300-225-0.75-TO-S1-G90
 产品规格书
www.raybowlaser.com

文件编号	RB-PN-10009283
版本号	V 2.0
页码	6 / 9

Typical Characteristic 典型参数图

Figure 1 : Power-Voltage-Current Characteristics

@ Pw=200 ns, f=5 kHz, Ta=25 °C

功率-电压-电流曲线

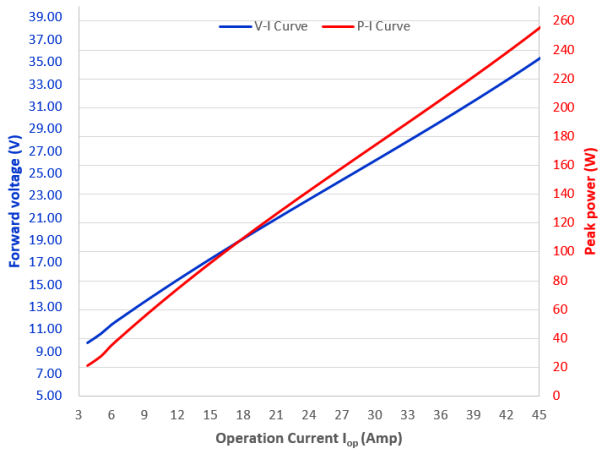

Figure 3 : Far Field Pattern Characteristics

@ I_{op} (Pw=200 ns, f=5 kHz), Ta=25 °C

远场发散角曲线

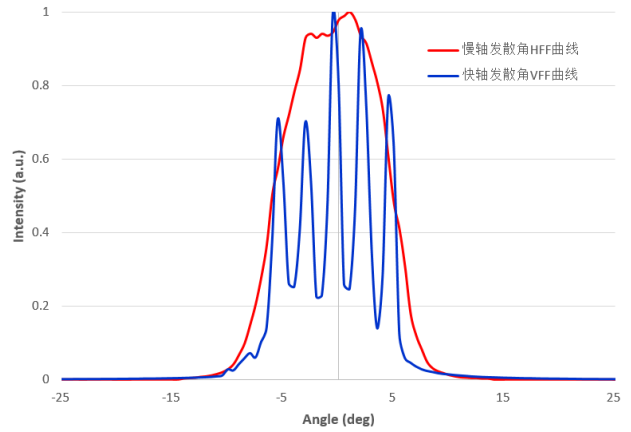
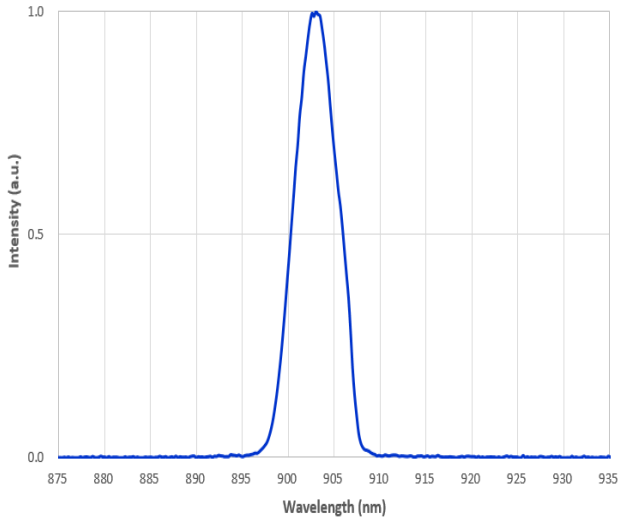

Figure 2 : Spectral Characteristics

@ I_{op} (Pw=200 ns, f=5 kHz) Ta=25 °C

光谱曲线



■ Dimensional Drawing 外观尺寸图 (清洁玻璃窗时禁用酒精等有机物)

备注：建议使用此芯片时热通道设计要足够好，否则芯片功率容易因热饱和而衰减)

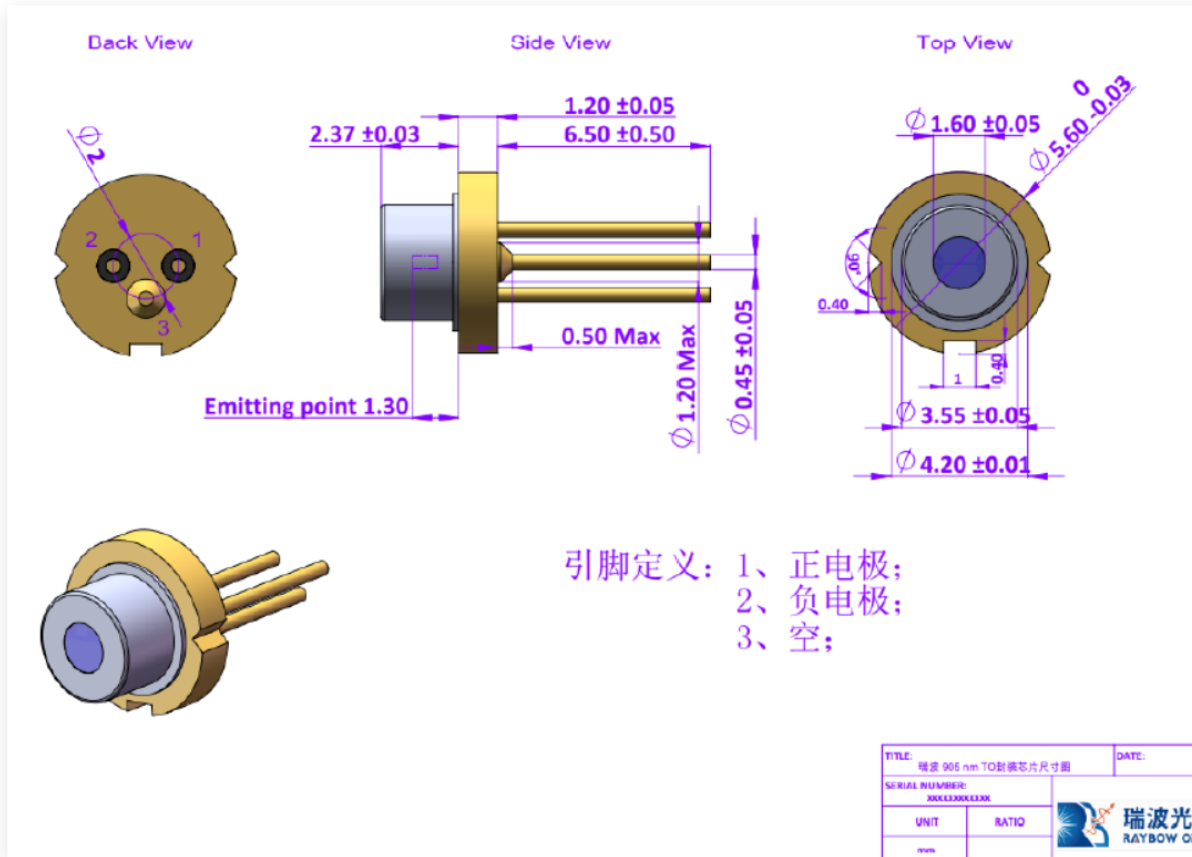

 瑞波光电 RAYBOW OPTO	RB-905E-300-225-0.75-TO-S1-G90 产品规格书 www.raybowlaser.com	文件编号	RB-PN-10009283
		版本号	V 2.0
		页码	8 / 9

■ Notes 注意事项

Product changes 产品变更

Specifications are subject to change without notice. No liability is assumed as a result of their use or application without confirming with our company.

此份规格书会在未通知的情况下进行更改。未与我司确认，参考此份规格造成的使用问题，我司不承担责任。

Safety considerations 安全考虑

Depending on the mode of operation, these devices emit highly concentrated non visible infrared light which can be hazardous to the human eye. Products which incorporate these devices have to follow the safety precautions given in IEC 60825-1 "Safety of laser products".

根据工作方式的不同，激光器件会发射非可见、高亮度的红外激光，这种激光会对人眼造成损害。使用这些激光器件的产品，应该遵守遵循 IEC 60825-1 中给出的安全预防措施。

Electrostatic protection 静电防护

Electrostatic discharge is the primary cause of unexpected laser diode failure. Take extreme precaution to prevent ESD. Use wrist straps, grounded work surfaces and rigorous antistatic techniques when handling diode lasers.

静电释放是很多无法预期半导体激光器失效的主要原因。需要使用良好的防护措施来避免静电。当使用半导体激光器时，建议佩戴静电手环，工作平台做好接地措施，或其他可靠的抗静电手段。

Operating conditions 工作条件

The RAYBOW warranty applies only to devices operated within the maximum rating, as specified. Exceeding these conditions is likely to cause permanent "burn off" damage to the laser facet and consequently a significant reduction in optical power.

Laser diode may be damaged when switch on and off of the power supply. A stabilizer should be taken into consideration for the power supply to prevent from the failure.

瑞波只对规格书限定使用条件的器件提供质量保证。超规格使用容易造成芯片腔面的光学灾变和明显的功率衰减。半导体激光器容易在驱动电源开关的时候受到损坏。建议对驱动电源增加稳定措施以避免激光器的失效。

Storage / Transportation Warm notice 存储/运输注意事项

The product may cause abnormal performance or degradation in the following storage environments

- (1) The product is exposed to sea winds or corrosive gas (Cl₂, H₂S, NH₃, SO₂, NO₂ and other gases)
- (2) The product is immersed in liquid (water, oil, chemicals, organic solvents, etc.)
- (3) The product is exposed to direct sunlight or dust.
- (4) The product is exposed to the temperature (-40~105°C) or relative humidity (RH=30%-80%) exceeding the specification value.
- (5) The product is exposed to an environment with a high accumulation of static electricity.

产品在以下存储环境中可能会导致性能异常或退化：

	RB-905E-300-225-0.75-TO-S1-G90 产品规格书 www.raybowlaser.com	文件编号	RB-PN-10009283
		版本号	V 2.0
		页码	9 / 9

- (1) 产品暴露在海风或腐蚀性气体 (Cl₂、H₂S、NH₃、SO₂、NO₂ 等气体) 中
- (2) 产品遭受液体 (水、油、化学品、有机溶剂等) 的浸泡
- (3) 产品暴露在阳光直射或粉尘中
- (4) 产品暴露在超过规格值的温度 (-40~105°C) 或相对湿度(RH=30%-80%) 的环境中。
- (5) 产品暴露在有较高的静电积累的环境中。

AEC-Q102 qualification AEC-Q102 认证

The complete qualification test plan in AEC-Q102 is not applicable for bare IR laser diode bare die. Only selected tests from AEC-Q102 which are deemed relevant for bare die-related failure mechanism are performed.

对于红外半导体激光器裸芯片做 AEC-Q102 的全部认证测试，并不适用。目前我司仅对 AEC-Q102 涉及到裸芯片的相关失效机制做了选择性测试。



Published by Shenzhen Raybow Optoelectronics Co., Ltd.

©all rights reserved

www.raybowlaser.com

此产品手册由深圳瑞波光电子有限公司制作

©保留所有权利

